

SUPERIOR

RFX™

User Manual and Parts List

P/n: D-19037

DOC#:024091

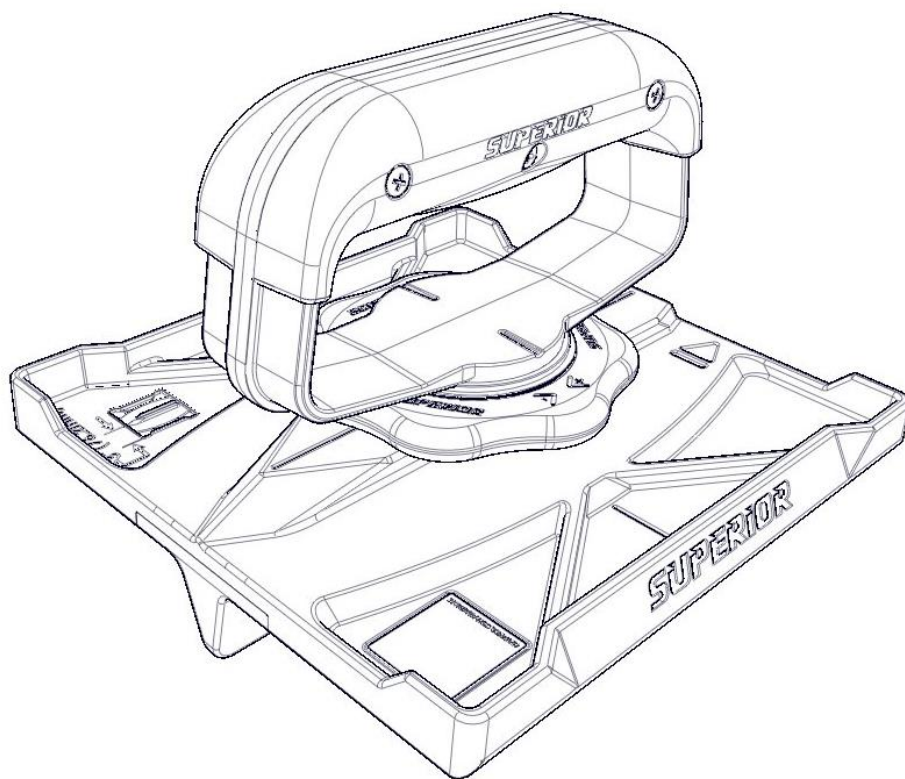

General**Safety symbols:**

WARNING! If used incorrectly the tool can cause injury.



Please read the Operator's Manual thoroughly making sure you understand how to use the tool before use.



Always wear personal protective equipment such as gloves, eye protection, hearing protection, and a hard hat. Jobsites might require certain protective equipment be used due to national and local regulations and insurance policies. Make sure you check with the jobsite foreman for requirements before work begins.

Dear Customer,

Thank you for choosing a Superior Innovation product. It is our intent to deliver the best products possible. Delivering innovative, well-built, ergonomic, efficient products is our goal to help you do the best job possible. Safety, and innovation are our cornerstone of our designs.

This Operator's Manual is a valuable document. Make sure it is always accessible when using the tool. If you lend or sell this tool, make sure that this document is also transferred, so the new user will know how to properly use and maintain it. Some of our products have a QR decal where the user can scan with a smartphone camera to access the manual. In addition, this document is available for download at www.superiorinnovationsinc.com/manuals.

User Responsibility

It is the owner's / employer's responsibility to ensure that the operator is properly trained and has sufficient knowledge about how to use this tool safely. Supervisors and operators must read and understand the operators Manual. They must be aware of the safety instructions, limitations, proper use and maintenance. Local and national legislation may regulate the use of this tool. Find out what legislations are applicable in your location before use.

Superior Innovations Reservation

All of the information and data in this Operator's Manual was up to date at the time the Operator's Manual was sent to print. Superior Innovations research and development is continually working on product development and improvements. Therefore, we reserve the right to modify the design, appearance and features of the product without prior notice. The most current version of manuals can be found at:
www.superiorinnovationsinc.com/manuals

Transportation and Storage

Secure the equipment during transportation to avoid transport damage and accidents.

After work is completed, remove the RFX™ fin from the RFX™-HG and thoroughly wipe down before the concrete has time to setup. **DO NOT USE A PRESSURE WASHER!**

Pressure washing can remove important safety decals, could remove the handles rubber coating or force water and debris into sealed chambers.

Personal Protective Equipment (PPE)

You must use approved personal protective equipment (PPE) whenever working. Personal protective equipment cannot eliminate injury, but it will reduce the degree of injury if an accident does happen. Ask your dealer for help in choosing the right protective equipment.

Common Sense

It is not possible to cover every conceivable situation in this document. Exercise care and use common sense if you get into a situation where you feel unsafe. Stop and seek expert advice by contacting Superior Innovations, Inc., a service dealer or an experienced user. Do not attempt any task that you are unsure of.

Work Area Safety

Observe your surroundings to ensure nothing can affect your control of the tools.

Observe your surroundings to ensure there is no risk of people or animals that can come into contact with the tools while in operation.

Do not use tools in bad weather, such as heavy rain, strong winds, intense cold, or heavy fog. Working in such weather is trying and can lead to difficult situations.

Ensure that the work area is sufficiently illuminated to create a safe working environment.

Make sure that there are no electrical cables routed in the working area.

Make sure that the work area is clear, clean and free of obstacles that can cause trips or spills.

Before Starting

Inspect equipment to ensure that there are no loose fasteners, cracks, leaks, or other obvious damage. If there are do not use until the problems are corrected.

Make sure that daily maintenance has been completed.

In the Box

The RFX™ is a component-based system where the user can use in many different configurations. What comes in the box is the most common configuration.

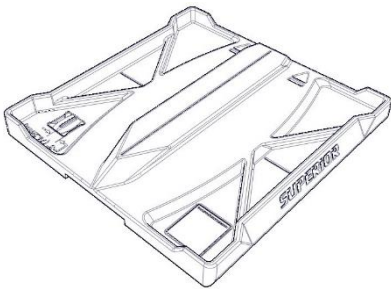

RFX™-HG



RFX™-DH

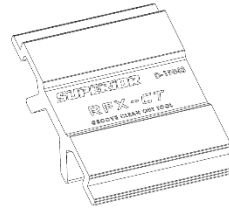

RFX™-CT

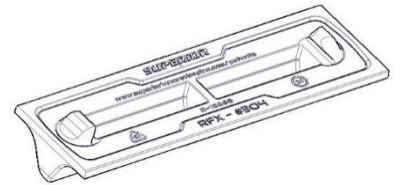

RFX™FIN

Optional Components



RFX™-CH

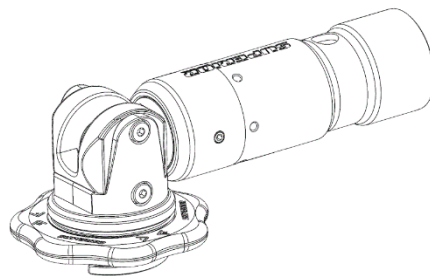

RFX™-PM

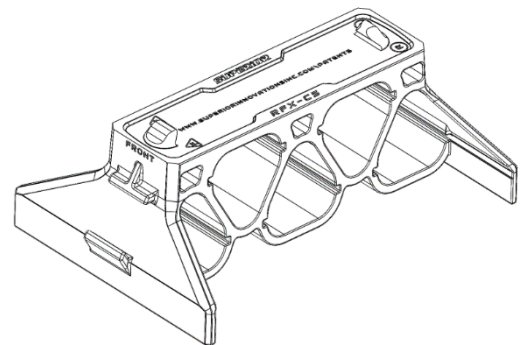

RFX™-C5

RFX™ - Model Nomenclature:

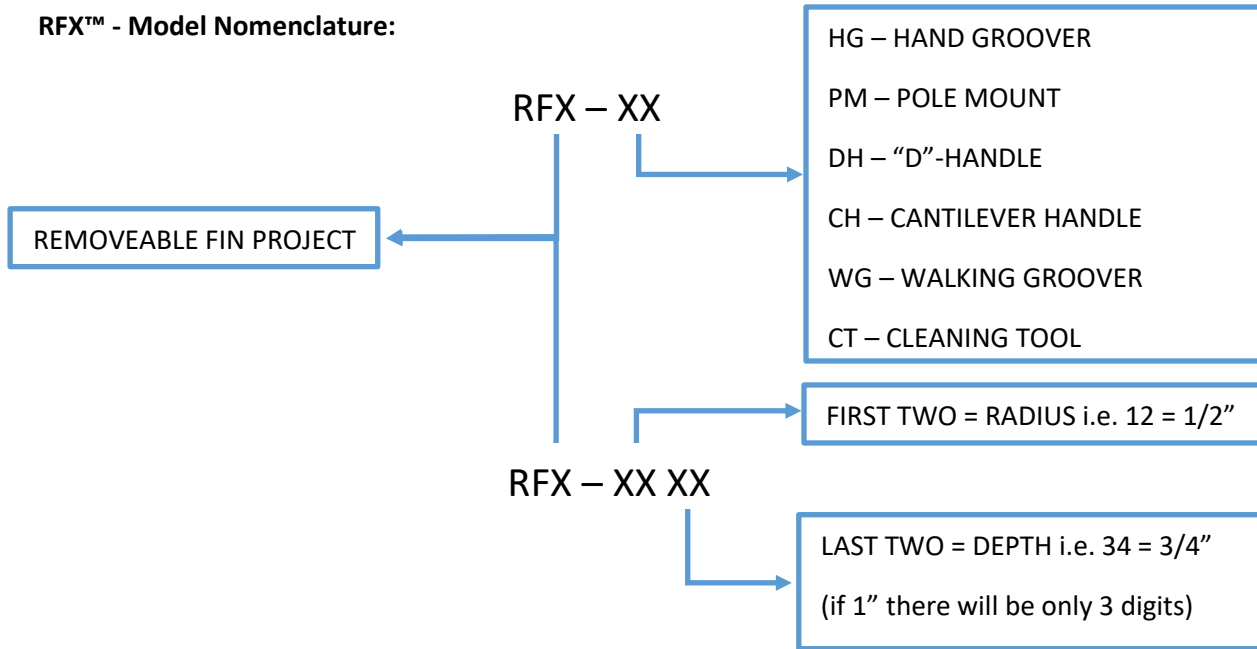

AVAILABILITY OF BLADE SIZES SUBJECT TO CHANGE. ADDITIONAL BLADES AND PRODUCTS WILL BE ADDED AS THEY BECOME AVAILABLE.

PART#	DECAL COLOR	MATERIAL	RADIUS	DEPTH	SPECIAL	MODEL NOMENCLATURE
D-18980	GREEN	AA380 DIE CAST	X	X	#304	RFX - #304
D-18976	RED	AA380 DIE CAST	X	X	#314	RFX - #314
D-18983	BLUE	AA380 DIE CAST	3/4	3/4	X	RFX - 3434
D-18986	YELLOW	AA380 DIE CAST	1/2	3/4	X	RFX - 1234
D-19007	GREY	AA380 DIE CAST	1/4	1/4	X	RFX - 1414
D-19001	PURPLE	AA380 DIE CAST	1/2	1/2	X	RFX - 1212

In addition to the model nomenclature, we have also color coded the RFX™ fin decal.



QAS

QUICK ATTACH SYSTEM

QAS™ is a quick attach system designed to make it quick and easy to attach Superior tools and even other manufacturers tools together. The ability to quickly Remove and attach modular components allows for easier setup, cleanup and the ability to configure your tools the way you prefer to use them.

The new RFX™ hand groover system relies on the QAS™ system to quickly change or position handles without any tools. In addition, the new RFX™-PM has a built-in QAS™ mount, so you can change your hand groover to a pole extension groover.

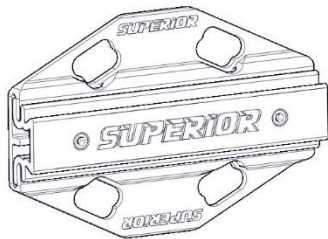

QAS™-M Adapter

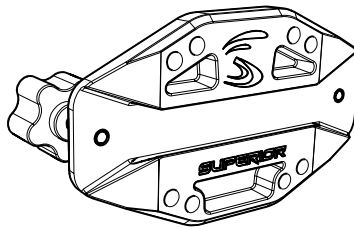

QAS™-F Adapter

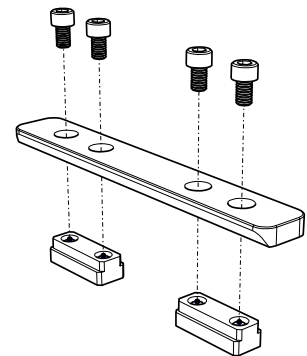

QAS™-W Adapter



RFX™-DH



RFX™-CH

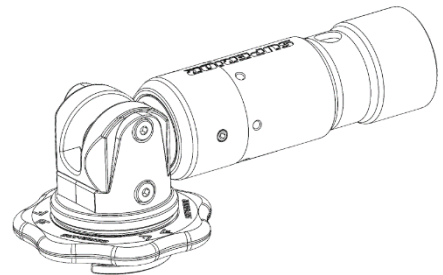

RFX™-PM

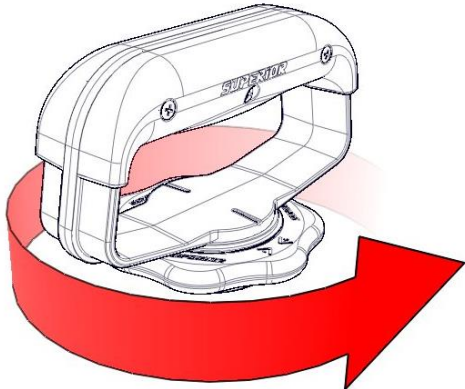
Attaching the RFX™ handle to the RFX™-HG

Loosen the QAS™ knob by rotating it counter-clockwise. The red colored pressure washer on the base of the QAS™ knob must be clear of the top surface of the QAS™ receptacle. Otherwise it will not slide over the male QAS™ on the RFX™-HG.

Align the QAS™ dovetail and slide over the male boss on the RFX™-HG.

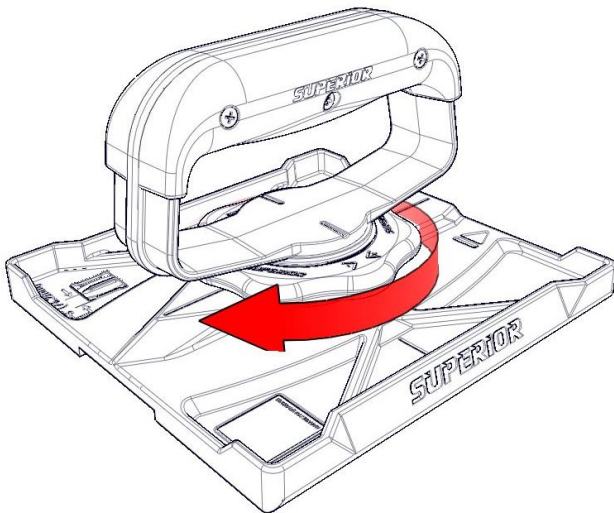
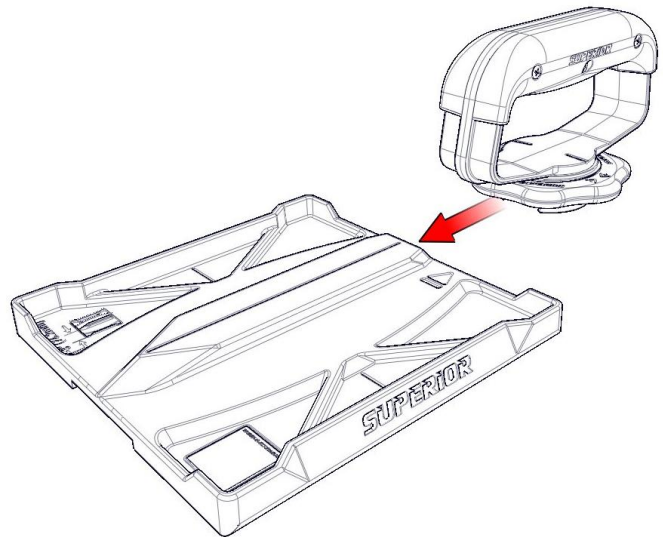

Position the RFX™-DH along the RFX™-HG base where ever desired and tighten the QAS™ knob by turning it clockwise until tight. **DO NOT OVERTIGHTEN**. The pressure washer will compress and add friction to help hold the handle in place.

Attaching the RFX™ fin

There is a difference between the two engagement tangs that hold the RFX™ fin in place. The taller tang is the rear of the fin and the shorter one is the front. The fin will only mount flat in the correct orientation.

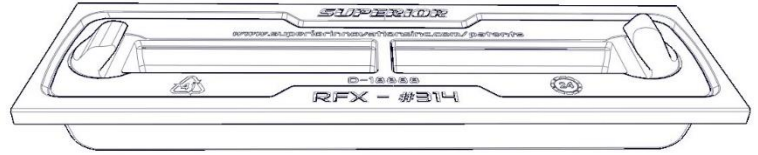

The Front of the RFX™ fin is identified by **F** and the rear by **R** on the decal.

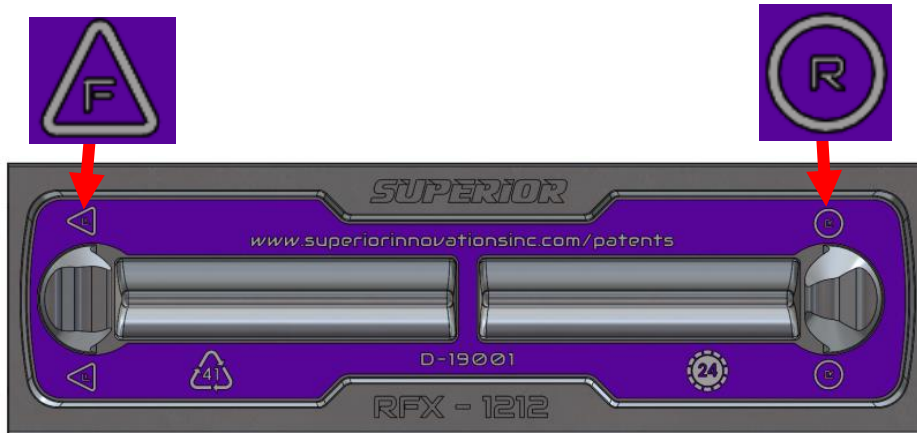

On the bottom of the RFX™-HG, you will see the same markings to identify the front and the rear.

Orient the RFX™ fin where the mounting tangs are facing the RFX™-HG and the F and R symbols are aligned.

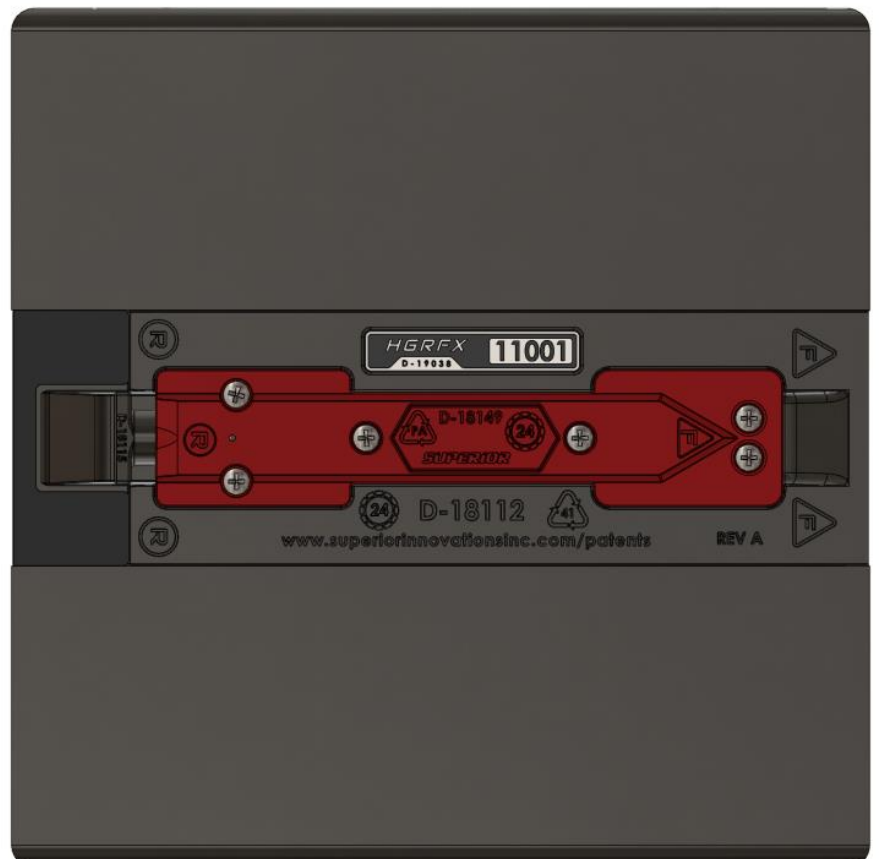

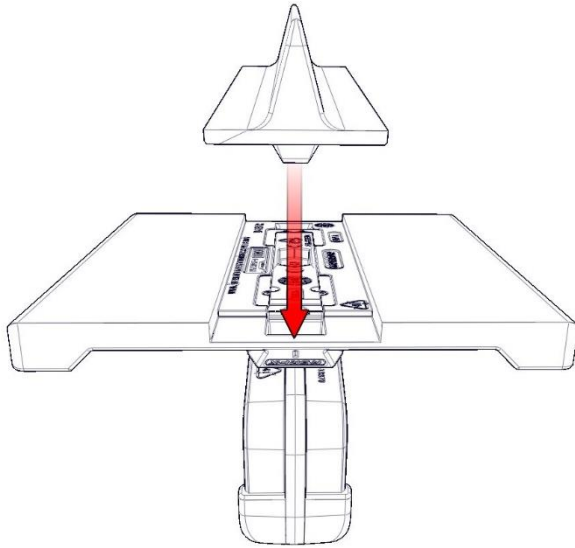

Slip the rear engagement tang into the rear receptacle of the RFX™-HG as shown. The rear engagement tang should pivot in the retaining pin marked with part number D-18115.

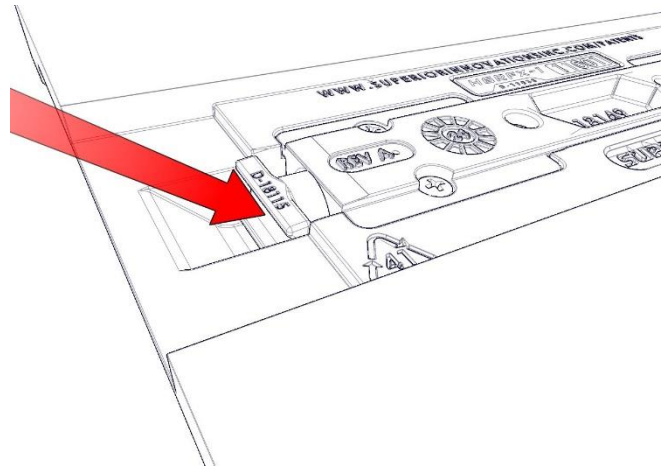

Once the rear tang is engaged, let the RFX™ fin lay flat in the channel and push the rear with your thumb as shown. The front tang will drop into the front engagement recess. Release the pressure from your thumb and the RFX™ fin will slide back and lock into place. **NOTE:** IF the RFX™ fin does not lay flat in the RFX™-HG channel, then remove the RFX™ fin and check for debris before re-installing.

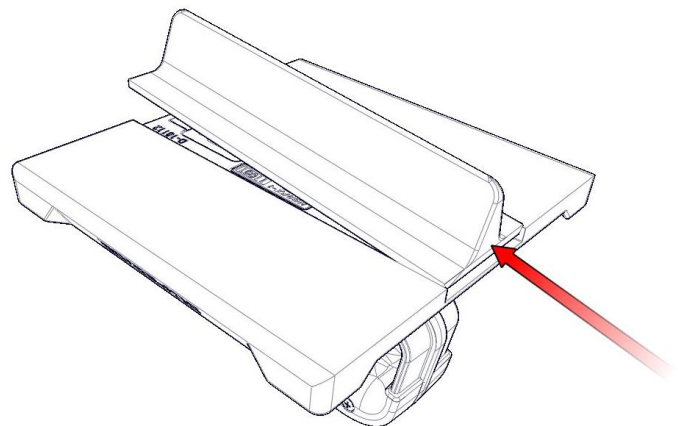

Removing the RFX™ fin

Push the rear of the fin with your thumb and the front engagement will slide forward and up. While applying pressure with your thumb; use another finger to lift on the front of the RFX™ fin to clear the front engagement. As you are holding the front up, release pressure from the rear of the RFX™ fin and lift out. Clean the RFX™-HG receptacle after every use for best results.

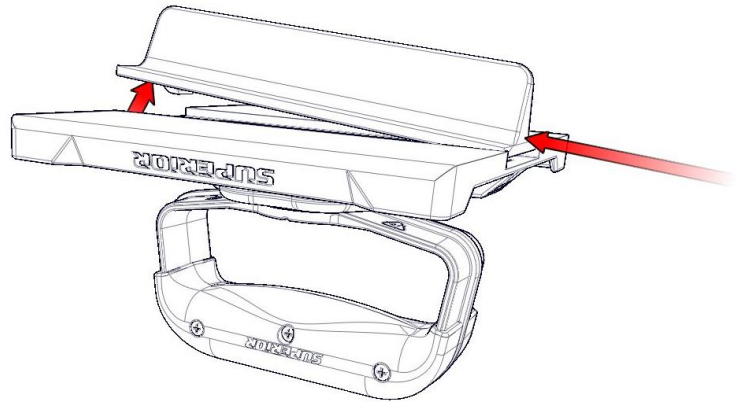
**Cleaning the RFX™-HG groove**

The RFX™ comes with a cleaning tool that will clean the receptacle groove as well as the QAS™ male. The tool is called RFX™-CT (D-19043). To use it, simply slide back and forth in the RFX™-HG receptacle groove. It will remove any debris that is adhered to the sides of the channel and the base.

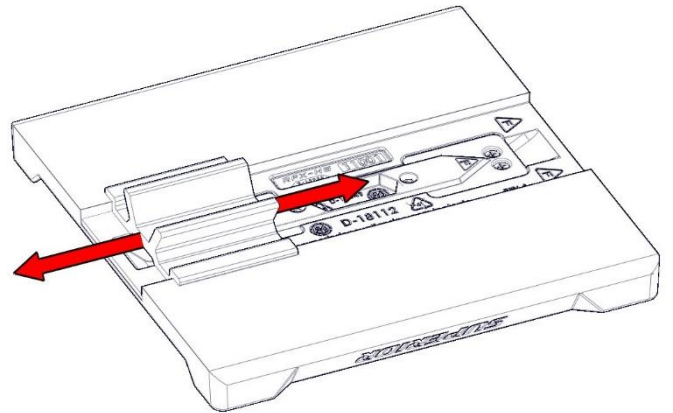
**Cleaning the RFX™-HG / QAS™ male**

Simply flip the RFX™-CT tool 180 degrees and slide it back and forth along the angle of each side of the QAS™ male as shown.

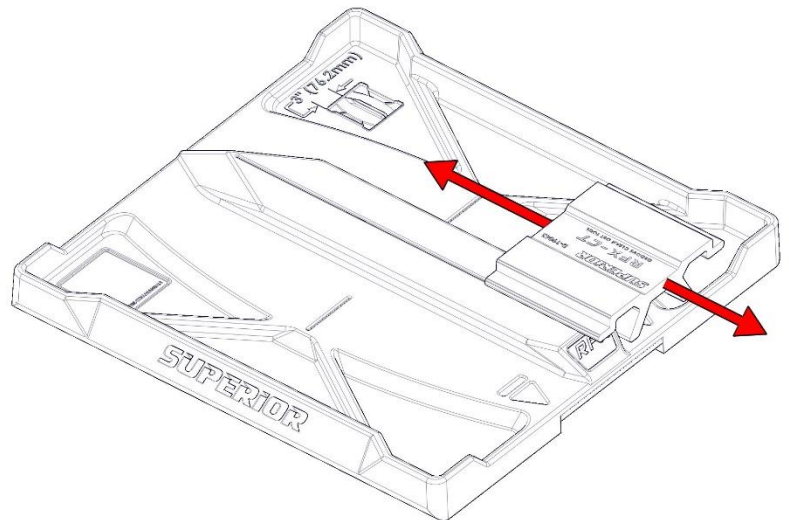

Attaching the RFX™-PM

Start by loosening the QAS™ knob by turning it counter clockwise until the pressure washer is above the QAS™ receptacle.

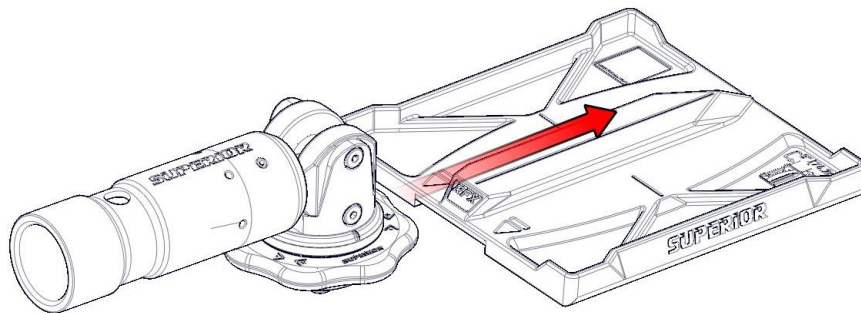
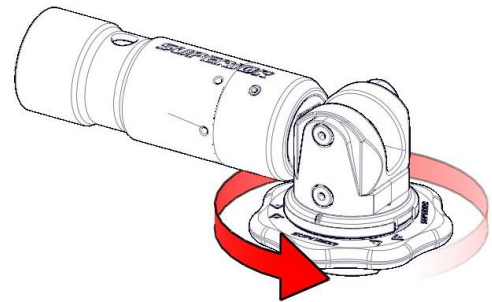

Next align the QAS™ male and female portions and slide the RFX™-PM onto the RFX™-HG

Position the RFX™-PM where you like along the RFX™-HG QAS™ male and tighten the QAS™ knob by turning it clockwise until tight. **DO NOT OVERTIGHTEN.**

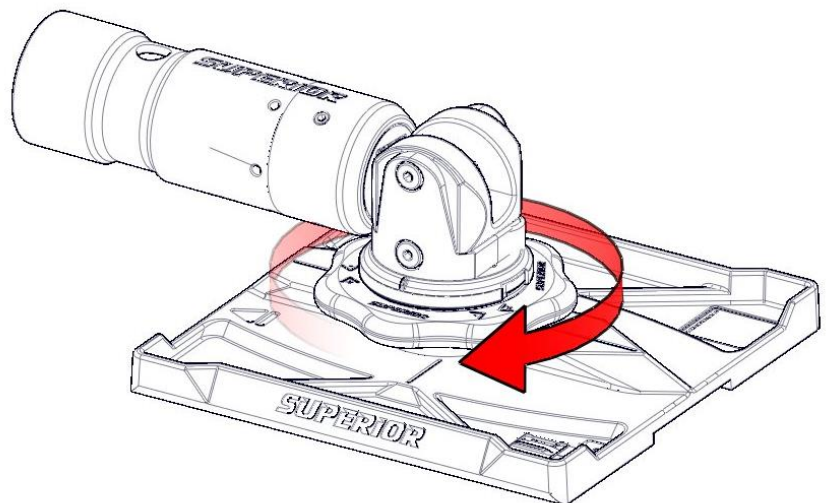

Attaching pole extension to the RFX™-PM

Depress and hold the pins on the pole extension. While continuing to holding the pins, slide the pole extension into the RFX-PM pole mount. When the pin centers are past the internal wall of the RFX-PM pole mount, let them go and slide the pole where the pins will expand outward and lock into the holes on the RFX-PM pole mount.

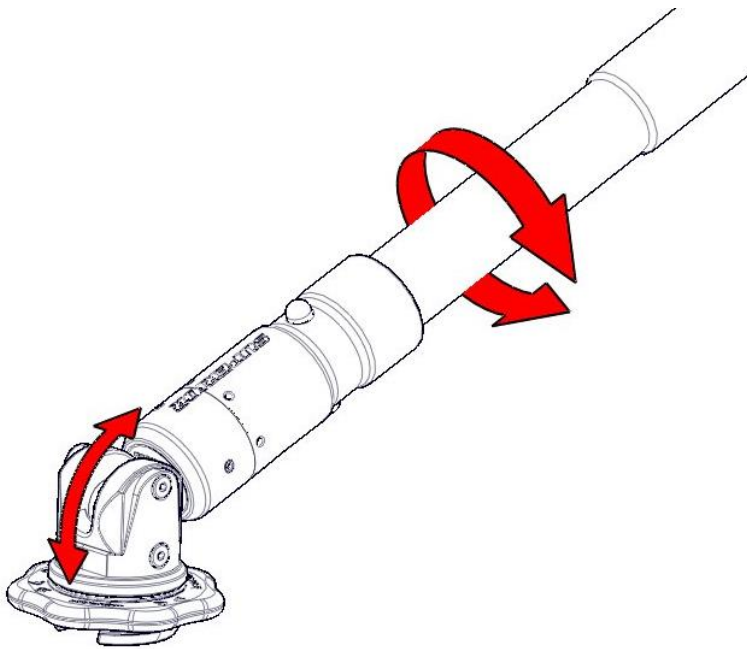
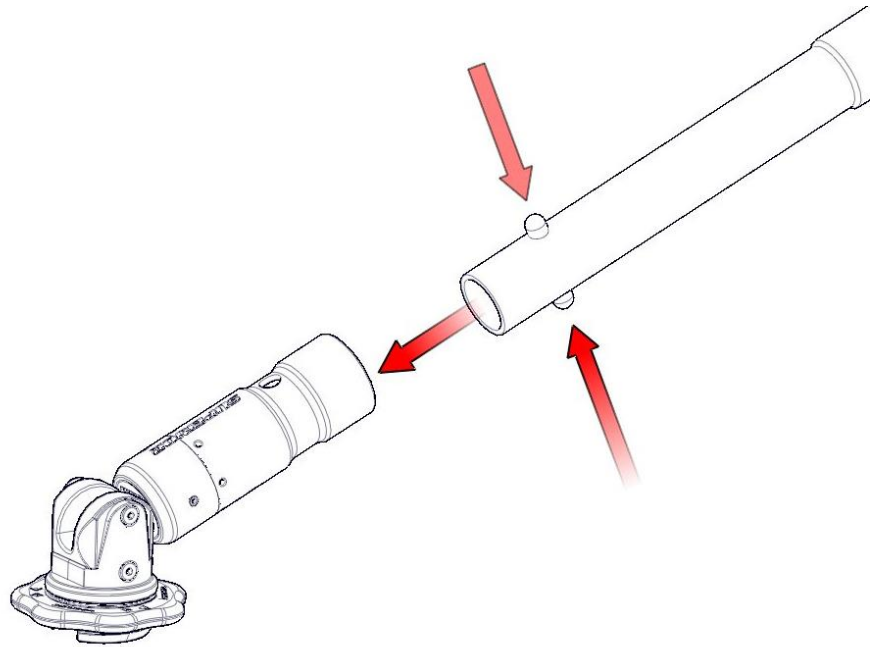
**Pitching the RFX™-PM**

Rotate the pole extension counter-clockwise to loosen the pivot. Once loose, pitch the pole in the desired position. Once in the desired position, rotate the pole extension clockwise to lock in place.

Rotating the QAS base

The QAS base can be rotated in 45-degree angle increments on the RFX-DH, RFX-CH and the RFX-PM. Shown below is the rotation on the RFX-DH, but is the same for the other two products.

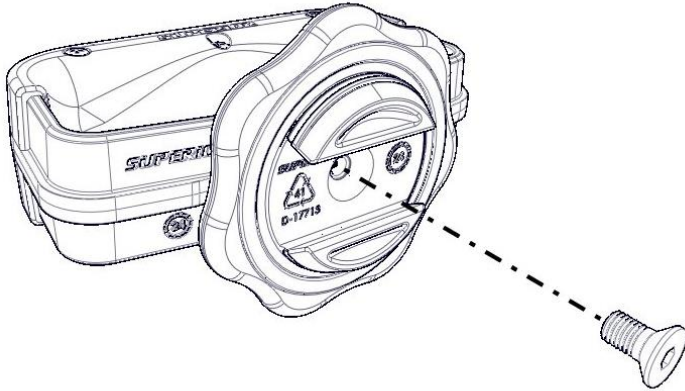

Remove the M6 flat head cap screw from the QAS base with a 4mm Allen key turning it counter-clockwise.

Pull the 80mm knob and QAS base until it detaches from the grooves on the mating component

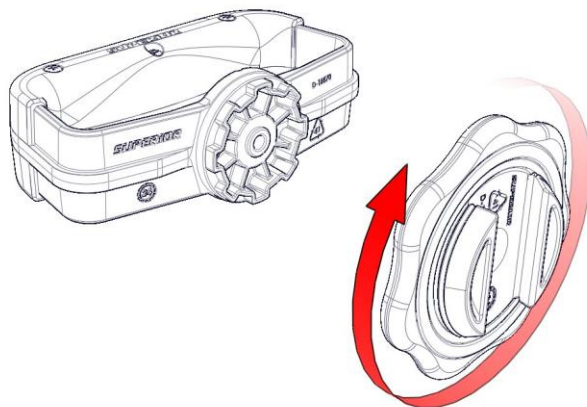
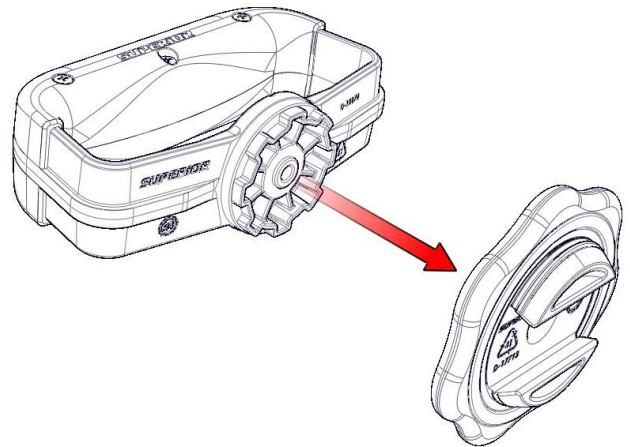

Rotate the QAS base to the desired position. The bosses will align with the cavity in the mating components in 45-degree angle increments.

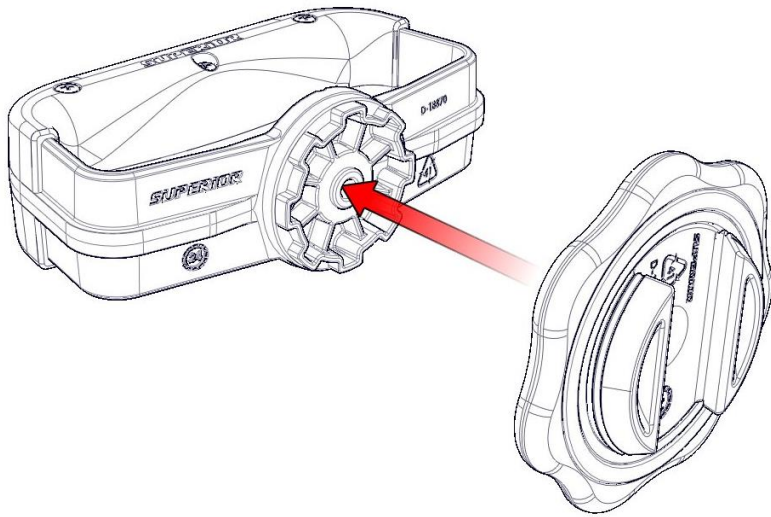

Align the bosses with the cavity and press firmly until it is seated in the desired position.

Reinstall the M6 flat head cap screw from into the QAS base with a 4mm Allen key turning it clockwise. Tighten, but do not overtighten.

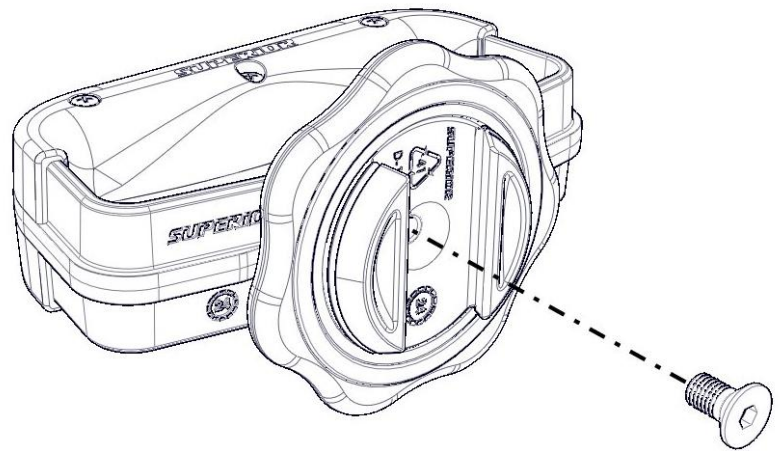

Maintenance Statement

The owner is responsible for the performance of all required maintenance, as described in the Operator’s Manual.

Remove RFX™ fin from the RFX™-HG receptacle and clean after use. If concrete sets-up around the QAS™ it may become difficult to use without cleaning. **DO NOT USE A PRESSURE WASHER.** The high-pressure water will remove important safety decals, could remove the TPE rubber coating from the handle, or force water into sealed cavities in the RFX™ receptacle system. You can use the supplied RFX™-CT cleaning tool to clean the groove and the QAS™ male.

Maintenance Schedule

Daily Maintenance	Weekly Maintenance	Monthly Maintenance
Cleaning (external)	Cleaning (external)	Cleaning (external)
Inspection	Inspection	Inspection
loose fasteners, cracks, leaks, or other obvious damage	loose fasteners, cracks, leaks, or other obvious damage	loose fasteners, cracks, leaks, or other obvious damage

Parts list / BOM

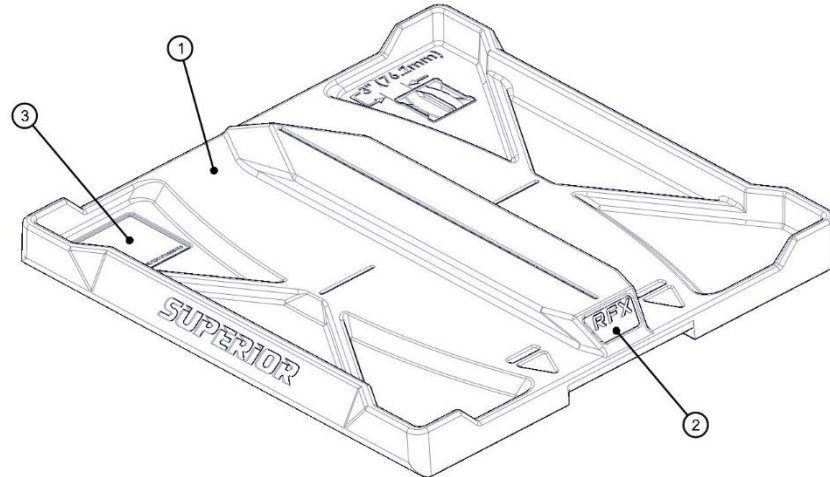

BOM ID	PART NUMBER	DESCRIPTION	QTY.
1	D-18112	RFX-HG MAIN FRAME	1
2	D-19039	RFX-HG BADGE	1
3	D-17624	QR ON-LINE MANUAL DECAL	1

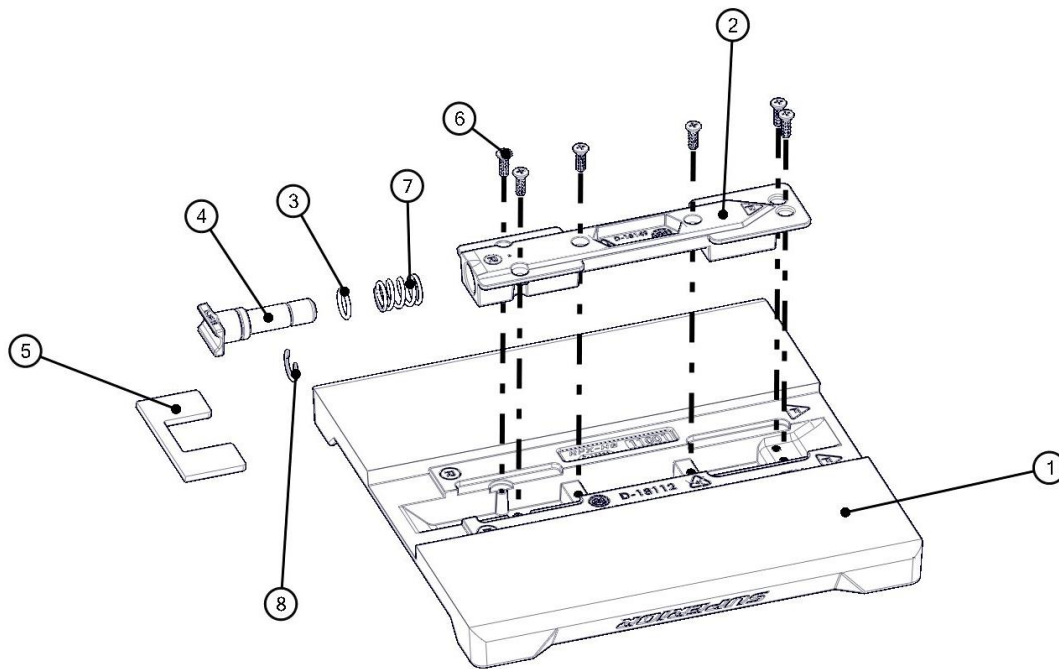

BOM ID	PART NUMBER	DESCRIPTION	QTY.
1	D-18112	RFX-HG MAIN FRAME	1
2	D-18149	RETAINER BLOCK	1
3	D-18540	SILICONE O-RING	1
4	D-18115	RETAINER PIN	1
5	D-18887	RFX-HG GASKET	1
6	D-19046	M2.5 X 0.45 X 8 OVAL HEAD MACHINE SCREW	6
7	D-16379	COMPRESSION SPRING	1
8	D-19045	C-RING - EXTERNAL	1

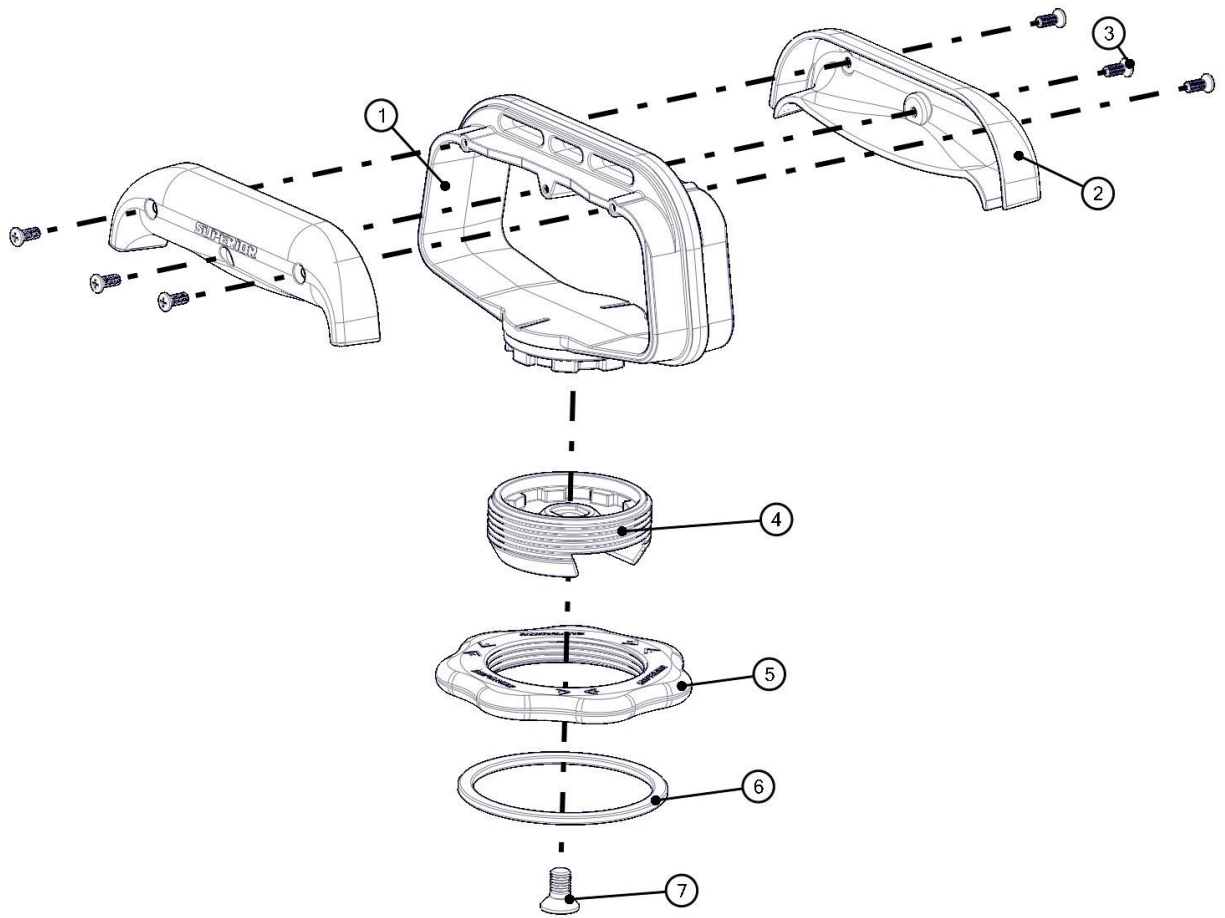

BOM ID	PART NUMBER	DESCRIPTION	QTY.
1	D-18870	RFX-DH MAIN CORE	1
2	D-18865	HANDLE GRIP	2
3	D-19046	M2.5 X 0.45 X 8 OVAL HEAD MACHINE SCREW	6
4	D-17713	RFX - QAS BASE	1
5	D-18867	RFX - QAS KNOB - 80MM	1
6	D-18868	QAS-KNOB PRESSURE WASHER	1
7	D-19047	M6 X 1 X 12 FLAT HEAD CAP SCREW	1

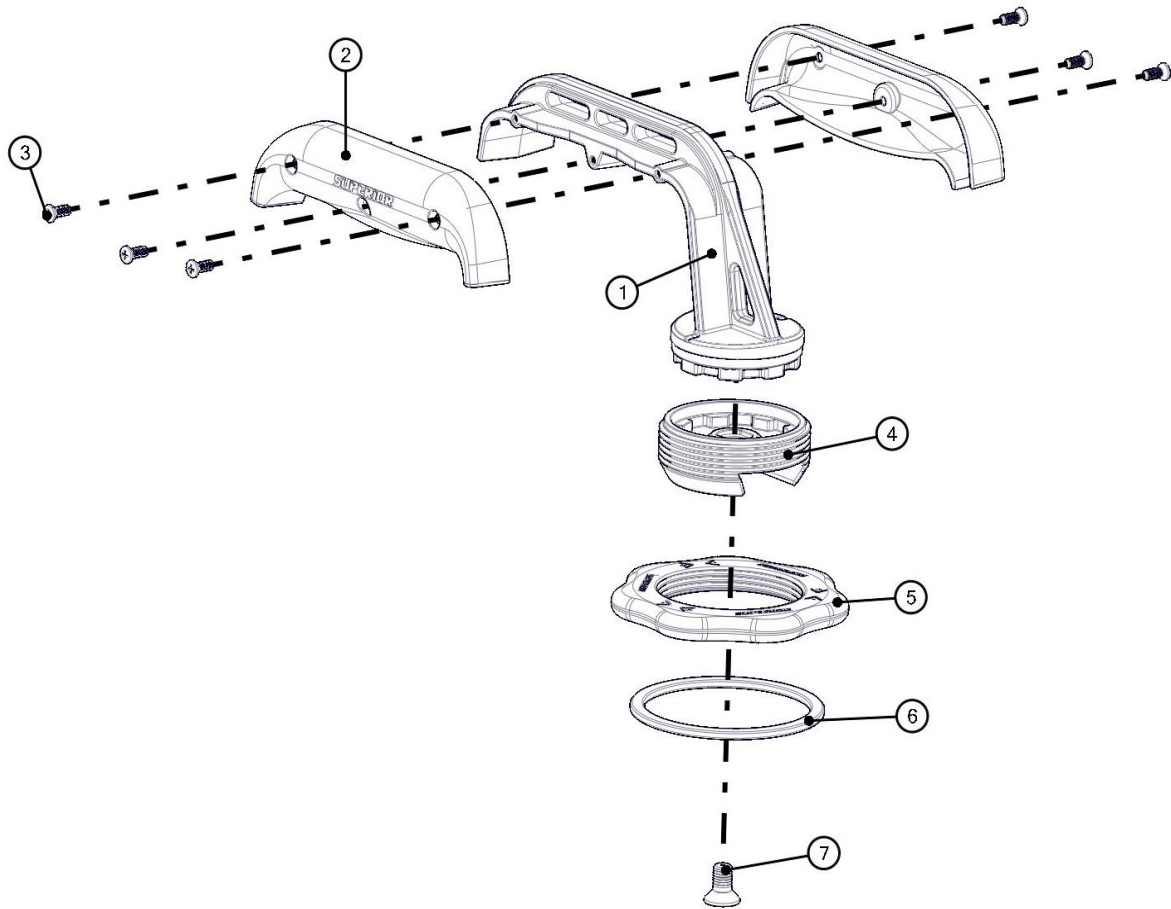

BOM ID	PART NUMBER	DESCRIPTION	QTY.
1	D-18877	RFX-CH MAIN CORE	1
2	D-18865	HANDLE GRIP	2
3	D-19046	M2.5 X 0.45 X 8 OVAL HEAD MACHINE SCREW	6
4	D-17713	RFX - QAS BASE	1
5	D-18867	RFX - QAS KNOB - 80MM	1
6	D-18868	QAS-KNOB PRESSURE WASHER	1
7	D-19047	M6 X 1 X 12 FLAT HEAD CAP SCREW	1

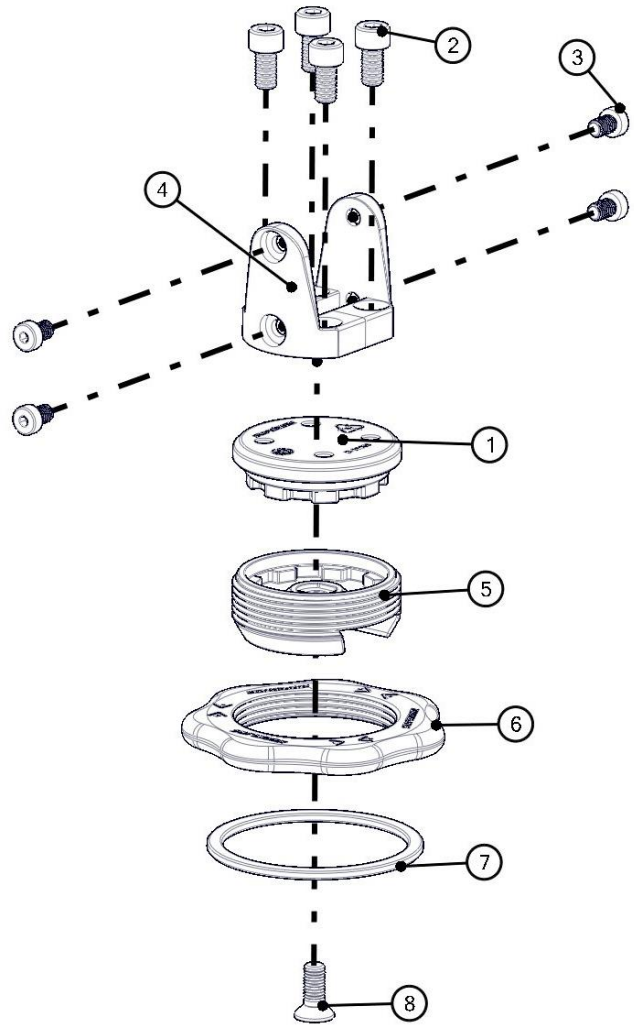
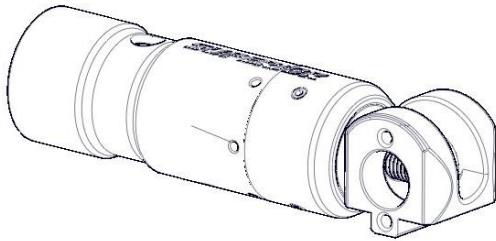

BOM ID	PART NUMBER	DESCRIPTION	QTY.
1	D-19008	RFX - PM TOP PLATE	1
2	D-19048	M6 X 1 X 12 SOCKET HEAD CAP SCREW	4
3	D-18863	M5 X 0.8 X 8 LOW HEAD CAP SCREW	4
4	D-18026	RFX - PM PIVOT HEAD	2
5	D-17713	RFX - QAS BASE	1
6	D-18867	RFX - QAS-KNOB - 80MM	1
7	D-18868	QAS-KNOB PRESSURE WASHER	1
8	D-19047	M6 X 1 X 12 FLAT HEAD CAP SCREW	1

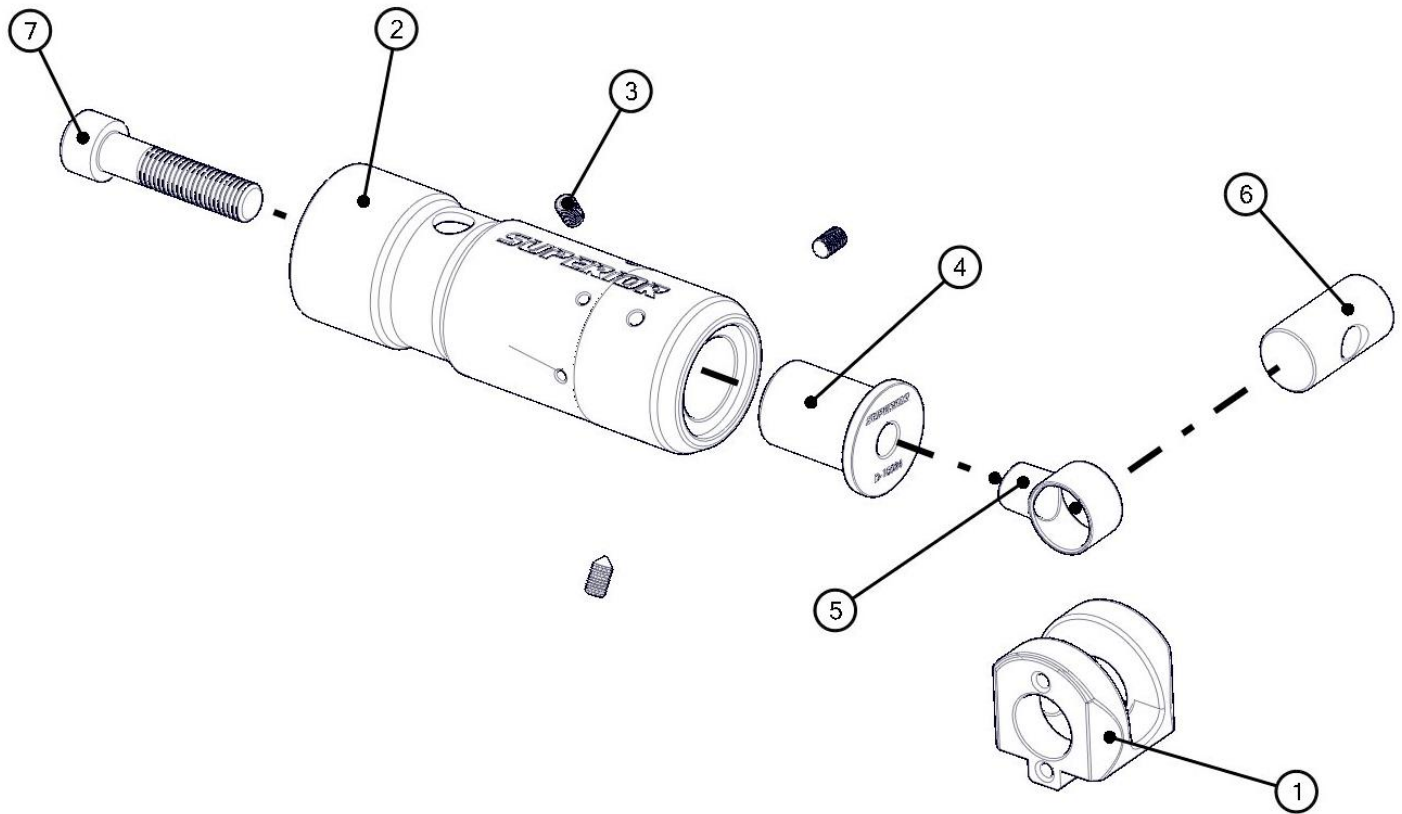

BOM ID	PART NUMBER	DESCRIPTION	QTY.
1	D-18027	RFX - PM PIVOT HEAD	1
2	D-18019	PIVOT HANDLE	1
3	D-19049	M5 X 0.8 X 8 SOCKET HEAD SET SCREW	3
4	D-18024	HANDLE MOUNT	1
5	D-18029	DUST GUARD	1
6	D-18860	SWIVEL PIN	1
7	D-19050	M10 X 1.5 X 45 SOCKET HEAD CAP SCREW	1

Technical Data

Dimensions		L	W	H
	RFX-HG	6.00 (152.5mm)	6.00 (152.5mm)	0.669 (17mm)
	RFX-#304	6.00 (152.5mm)	1.77 (45mm)	1.21 (30.85mm)
	RFX-#314	6.00 (152.5mm)	1.77 (45mm)	1.46 (37.20mm)
	RFX-3434	6.00 (152.5mm)	1.77 (45mm)	1.21 (30.85mm)
	RFX-1234	6.00 (152.5mm)	1.77 (45mm)	1.21 (30.85mm)
	RFX-1434	6.00 (152.5mm)	1.77 (45mm)	1.21 (30.85mm)
	RFX-341	6.00 (152.5mm)	1.77 (45mm)	1.46 (37.20mm)
	RFX-121	6.00 (152.5mm)	1.77 (45mm)	1.46 (37.20mm)
	RFX-3834	6.00 (152.5mm)	1.77 (45mm)	1.21 (30.85mm)
	RFX-1212	6.00 (152.5mm)	1.77 (45mm)	0.96 (24.5mm)
	RFX-DH	5.03 (128.0mm)	3.31 (84.15mm)	3.17 (80.5mm)
	RFX-CH	6.43 (163.5mm)	6.00 (152.5mm)	6.00 (152.5mm)
	RFX-C5	7.89 (200.5mm)	5.14 (130.65mm)	2.95 (75.00mm)
	RFX-CT	1.57 (40.0mm)	2.16 (55.0mm)	0.57 (14.5mm)
	RFX-PM	7.10 (180.3mm)	3.31 (84.15mm)	2.65 (67.3mm)
Mass	RFX-HG	0.880#, (399.0g)		
	RFX-#304	0.230#, (104.3g)		
	RFX-#314	0.224#, (101.6g)		
	RFX-3434	0.248#, (112.5g)		
	RFX-1234	0.220#, (99.8g)		
	RFX-1434	0.193#, (87.5g)		
	RFX-341	0.280#, (127.0g)		
	RFX-121	0.240#, (108.8g)		
	RFX-3834	0.197#, (89.4g)		
	RFX-1212	0.176#, (79.8g)		
	RFX-DH	0.560#, (254.0g)		
	RFX-CH	0.510#, (231.3g)		
	RFX-C5	0.480#, (217.7g)		
RFX-CT	0.060#, (27.2g)			
RFX-PM	1.42#, (644.1g)			
Mounting / Attachment	Quick Attach System (QAS™) integrated in RFX™-HG, RFX™-DH, RFX™-CH, RFX™-PM			
Materials	Fits on all superior RFX™ hand tools			
	AA380 (Recyclable - code 41), hard anodized			
	PA6-GFR30 Plastic			
	Stainless steel			
AISI 1020 steel, MIL A, 8625 C, TYPE II, CLASS 2, CLEAR				

Warranty

New equipment sold by Superior Innovations is warranted to be free from manufacturing defects under normal service for a period of one (1) year from date of purchase by the original consumer. Component manufacturers offer separate warranties and are covered separately. For complete information or to request a return goods authorization number (RGA#) call technical service at (844) 624-8423.

Superior Innovation's obligation under this warranty is expressly limited to the replacement or repair at our service facility or one that has been pre-authorized by Superior Innovations.

This warranty does not apply to defects caused by damage, unreasonable use, faulty repairs made by others or defects caused by failure to provide reasonable maintenance, while in the possession of the consumer. Further, the warranty is void if the product, or any of its components, is altered or modified by the consumer or if the product is used in an inappropriate manner not recommended by the manufacturer.

The RFX™-HG is a serialized product, so proof of purchase noting the serial number is required when evaluating any warranty claims. The serial number can be found on the bottom of the RFX-HG as shown below.

